

Iterative Feedback Tuning in Fuzzy Control Systems. Theory and Applications

Stefan Preitl, Radu-Emil Precup

Department of Automation and Applied Informatics,
“Politehnica” University of Timisoara
Bd. V. Parvan 2, RO-300223 Timisoara, Romania
E-mail: stefan.preitl@aut.upt.ro, radu.precup@aut.upt.ro

János Fodor

Institute of Intelligent Engineering Systems, Budapest Tech
Bécsi út 96/B, H-1034 Budapest, Hungary
E-mail: fodor@bmf.hu

Barnabás Bede

Department of Mechanical and System Engineering, Budapest Tech
Népszínház utca 8, H-1081 Budapest, Hungary
E-mail: bede.barna@bgk.bmf.hu

Abstract: The paper deals with both theoretical and application aspects concerning Iterative Feedback Tuning (IFT) algorithms in the design of a class of fuzzy control systems employing Mamdani-type PI-fuzzy controllers. The presentation is focused on two-degree-of-freedom fuzzy control system structures resulting in one design method. The stability analysis approach based on Popov's hyperstability theory solves the convergence problems associated to IFT algorithms. The suggested design method is validated by real-time experimental results for a fuzzy controlled nonlinear DC drive-type laboratory equipment.

Keywords: Iterative Feedback Tuning, PI-fuzzy controllers, experiments

1 Introduction

PI and PID controllers are widely used in more than 80% of industrial applications worldwide due to the good control system (CS) performance they offer [1]. Since the main tasks in control, the achievement of good CS performance in reference input tracking and the regulation in the presence of disturbance inputs, are difficult to be accomplished by means of PI and PID controllers in one-degree-of-freedom structures, an alternative is to develop two-degree-of-freedom (2-DOF) controllers which have advantages over the one-degree-of-freedom ones [2, 3]. However, the main drawback of 2-DOF control structures in the linear case is that although they ensure regulation, the reduction of the overshoot is paid by slower responses with respect to the modification of reference input. The presentation in the paper will be concentrated on the 2-DOF PI controller case.

Another solution with to ensure good CS performance in the conditions of complex or even ill-conditioned plants is represented by fuzzy control. The development of fuzzy control systems (FCSs) is usually performed by heuristic means, incorporating human skills, with the drawback in the lack of general-purpose design methods. A major problem, which follows from this way to design fuzzy controllers (FCs) is the analysis of several properties of the FCS including stability, controllability, parametric sensitivity and robustness [4, 5].

If low cost automation solutions are required then systematic design methods devoted to relatively simple FCs. One approach is to design firstly 2-DOF PI controllers for the plants characterized by simplified linearized models. Then, the transfer of results from the linear case to the fuzzy one resulting in 2-DOF PI-fuzzy controllers (PI-FCs) is done in terms of the modal equivalence principle [6] accepting the well acknowledged equivalence in certain conditions between FCSs and linear / linearized CSs [7].

Iterative Feedback Tuning (IFT) [8, 9] is a gradient-based approach, based on input-output data recorded from the closed-loop system. The CS performance indices are specified through certain cost functions (c.f.s). Optimizing such functions usually requires iterative gradient-based minimization, implemented as IFT algorithms, observing that the c.f.s can be complicated functions of the plant and of the disturbances dynamics. The key feature of IFT is that the closed-loop experimental data are used to compute the estimated gradient of the c.f. Several experiments are performed iteratively and the updated controller parameters are obtained based on the closed-loop input-output data obtained during system operation.

In this context, the aim of combining IFT algorithms with fuzzy control in terms of transferring the results from the linear case to the fuzzy one is to obtain new and attractive low cost fuzzy control solutions ensuring FCS performance enhancement.

One problem associated to any gradient-based optimization algorithm is related to its convergence. Solving this problem is done in a transparent way by the stability analysis. The paper presents a stability analysis approach based on Popov's hyperstability theory. This approach results in sufficient stability conditions that guarantee the convergence of the IFT algorithms.

The paper is organized as follows. An overview on the IFT algorithms used in tuning the linear 2-DOF PI controllers is presented in Section 2. Then, Section 3 is focused on a new design method for a class of Mamdani-type two-degree-of-freedom PI-fuzzy controllers (2-DOF PI-FCs). Section 4 deals with the stability analysis of the considered class of FCs in order to guarantee the convergence of IFT algorithms. Section 5 is dedicated to the validation of the method by applying it in one case study regarding the speed control of a nonlinear DC drive-type laboratory equipment, and the last Section 6 to conclusions.

2 Overview on Iterative Feedback Tuning Algorithms

Two versions of equivalent control system structures can be used in case of 2-DOF control structures to ensure either simultaneous tuning of controller parameters [10] or their separate tuning for each of the controller blocks [11]. The first version will be presented as follows, with the nomenclature according to Fig. 1(a), where the two controller blocks are characterized by the transfer functions $C_r(s)$ and $C_y(s)$. The basic details in the 2-DOF control structure case are presented in [12].

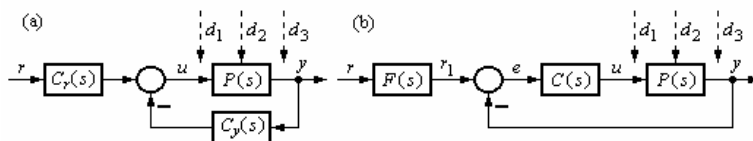

Figure 1

2-DOF control system structure used in IFT (a), and used feedforward filter (b)

The IFT method consists of the steps A) ... E) to be presented in the sequel in relation with the 2-DOF PI controller having the structure presented in Fig. 1(b), where: $C(s)$ – transfer function of the main PI controller:

$$C(s) = k_c(1 + sT_i)/s = k_c[1 + 1/(sT_i)], \quad k_c = T_i k_c, \quad (1)$$

with k_c – controller gain and T_i – integral time constant, $F(s)$ – transfer function of the feedforward filter:

$$F(s) = 1/(1 + T_i s), \quad (2)$$

r – reference input, y – controlled output, $e = r_1 - y$ – control error, u – control signal, r_1 – output of block $F(s)$ (filtered reference input), d_1, d_2, d_3 – load disturbance input scenarios, with the general disturbance input $d \in \{d_1, d_2, d_3\}$, and the connections between the controller blocks in Fig. 1(a) and (b) are:

$$C_r(s) = C(s)F(s), \quad C_y(s) = C(s). \quad (3)$$

In these conditions, the steps of the IFT approach are:

A) A controller, of desired complexity, which stabilizes the system, has to be chosen. A discrete form of the controller is needed. The parameterization of the controller is such that the transfer functions $C_r(s, \boldsymbol{\rho})$ and $C_y(s, \boldsymbol{\rho})$ are differentiable with respect to its parameters, $\boldsymbol{\rho}$ being the parameter vector.

For the sake of highlighting the controller tuning parameters, the parameter vector $\boldsymbol{\rho}$ has been added as additional input variable to the transfer function. This nomenclature will be used in the sequel in both continuous- and discrete-time not only for the transfer functions but also to the variables regarding the plant (the control signal u and the controlled output y).

B) A reference model must be chosen, prescribing the desired CS behaviour observed in y . This model is typically chosen with first- or second-order dynamics and, for the sake of simplicity and better CS performance, it can be also chosen to be without dynamics, having the transfer function equal to the unity.

C) The general expression of the c.f. J is proposed in (4) in the framework of this optimization problem:

$$\boldsymbol{\rho}^* = \underset{\boldsymbol{\rho} \in SD}{\text{arg min}} J(\boldsymbol{\rho}), \quad J(\boldsymbol{\rho}) = \frac{1}{2N} \cdot \sum_{k=1}^N \{ [L_y(q^{-1}) \delta y(k, \boldsymbol{\rho})]^2 + [L_u(q^{-1}) u(k, \boldsymbol{\rho})]^2 \}, \quad (4)$$

where: N – length of each experiment, L_y, L_u – weighting filters, introduced to emphasize certain frequency regions, λ – weighting constant, δy – output error, the difference between the actual output (y) and the desired output (y_d):

$$\delta y = y - y_d. \quad (5)$$

D) The update law must be set by which the next set of parameters will be computed. This law corresponds usually to a Gauss-Newton scheme of type (6), other versions being also used to avoid the computation of second-order derivatives:

$$\boldsymbol{\rho}^{i+1} = \boldsymbol{\rho}^i - \gamma^i (\mathbf{R}^i)^{-1} \text{est} \left[\frac{\partial J}{\partial \boldsymbol{\rho}}(\boldsymbol{\rho}^i) \right], \quad (6)$$

where: i – index of the current iteration, $est[x]$ – estimate (generally) of the variable x , $\gamma^i > 0$ – parameter to determine the step size.

E) The regular matrix \mathbf{R}^i in (6) is a positive definite matrix, usually the Hessian of $J(\boldsymbol{\rho})$:

$$\mathbf{R}^i = \frac{1}{N} \sum_{k=1}^N \left(est \left[\frac{\partial y}{\partial \boldsymbol{\rho}}(k, \boldsymbol{\rho}^i) \right] est \left[\frac{\partial y}{\partial \boldsymbol{\rho}}(k, \boldsymbol{\rho}^i) \right]^T + \lambda est \left[\frac{\partial u}{\partial \boldsymbol{\rho}}(k, \boldsymbol{\rho}^i) \right] \cdot est \left[\frac{\partial u}{\partial \boldsymbol{\rho}}(k, \boldsymbol{\rho}^i) \right]^T \right) \quad (7)$$

Choosing the identity matrix for \mathbf{R}^i ensures the negative direction of the gradient, but it is recommended to compute \mathbf{R}^i by a quasi-Newton method or as the Hessian of the c.f.

IFT algorithms are employed to implement to solve the optimization problem (4), where several additional constraints can be imposed regarding the plant or the closed-loop system. One necessary constraint concerns the stability of the closed-loop system, and SD in (4) stands for stability domain. In addition, the expression of the c.f. can be modified by adding quadratic terms with the output sensitivity functions defined in the time domain, accordingly weighted to reduce the sensitivity of the CS with respect to the parametric variations of the controlled plant (see the situation in [13] for FCSs).

The iterative character of IFT algorithms in case of 2-DOF PI controllers considered here results from three real-time experiments performed with the CS, the first and the third one referred to as normal ones and the second one referred to as the gradient one. The normal experiments are characterized by the reference input fed to the CS while in case of the gradient experiment the role of reference input fed to the CS is played by the control error in the first experiment. The input-output data recorded from these three experiments are employed to compute the estimated gradients of the controlled output and of the control signal required in computing the estimated gradient of the c.f. $J(\boldsymbol{\rho})$.

The IFT algorithms considered here contain the steps 1 ... 8 to obtain the next set of parameters:

Step 1 The three experiments are done and the input-output data (u_1, y_1) , (u_2, y_2) and (u_3, y_3) are recorded.

Step 2 The output of the reference model is generated, y_d , and the output error δy is computed by (5).

Step 3 The estimated gradient of the output is computed based on the data recorded from the real-time experiments. Before applying this approximation, the sensitivity function S and the complementary sensitivity function T must be

expressed in discrete-time, with the following definitions according to the CS structure illustrated in Fig. 1(a):

$$\begin{aligned} S(q^{-1}, \boldsymbol{\rho}) &= 1/[1 + P(q^{-1})C_y(q^{-1}, \boldsymbol{\rho})], \\ T(q^{-1}, \boldsymbol{\rho}) &= P(q^{-1})C_r(q^{-1}, \boldsymbol{\rho})/[1 + P(q^{-1})C_y(q^{-1}, \boldsymbol{\rho})]. \end{aligned} \quad (8)$$

The analytical expression of the gradient of δy is obtained using (8) and taking the derivatives with respect to $\boldsymbol{\rho}$ [10]:

$$\begin{aligned} \text{est} \left[\frac{\partial \delta y}{\partial \boldsymbol{\rho}}(k, \boldsymbol{\rho}) \right] &= \frac{1}{C_r(q^{-1}, \boldsymbol{\rho})} \cdot \left[\frac{\partial C_r}{\partial \boldsymbol{\rho}}(q^{-1}, \boldsymbol{\rho}) y_3(k, \boldsymbol{\rho}) - \right. \\ &\quad \left. - \frac{\partial C_y}{\partial \boldsymbol{\rho}}(q^{-1}, \boldsymbol{\rho}) y_2(k, \boldsymbol{\rho}) \right]. \end{aligned} \quad (9)$$

Step 4 The control signal is a perfect realization of the control signal in the first experiment:

$$u = u_1. \quad (10)$$

Step 5 The estimated gradient of the control signal u is computed using (8), (10) and taking the derivatives with respect to $\boldsymbol{\rho}$:

$$\begin{aligned} \text{est} \left[\frac{\partial u}{\partial \boldsymbol{\rho}}(k, \boldsymbol{\rho}) \right] &= \frac{1}{C_r(q^{-1}, \boldsymbol{\rho})} \cdot \left[\frac{\partial C_r}{\partial \boldsymbol{\rho}}(q^{-1}, \boldsymbol{\rho}) u_3(k, \boldsymbol{\rho}) - \right. \\ &\quad \left. - \frac{\partial C_y}{\partial \boldsymbol{\rho}}(q^{-1}, \boldsymbol{\rho}) u_2(k, \boldsymbol{\rho}) \right]. \end{aligned} \quad (11)$$

Step 6 The c.f. $J(\boldsymbol{\rho})$ is computed according to (4) with the estimated and its estimated gradient results as follows:

$$\begin{aligned} \text{est} \left[\frac{\partial J}{\partial \boldsymbol{\rho}}(\boldsymbol{\rho}) \right] &= \frac{1}{N} \sum_{k=1}^N \{ L_y(q^{-1}) \delta y(k, \boldsymbol{\rho}) \text{est} \left[\frac{\partial \delta y}{\partial \boldsymbol{\rho}}(k, \boldsymbol{\rho}) \right] + \\ &\quad + \lambda L_u(q^{-1}) u(k, \boldsymbol{\rho}) \text{est} \left[\frac{\partial u}{\partial \boldsymbol{\rho}}(k, \boldsymbol{\rho}) \right] \}, \end{aligned} \quad (12)$$

with the values of the estimated gradients obtained as steps 3 and 5.

Step 7 The matrix \mathbf{R}^i is computed in terms of (7).

Step 8 The next set of parameters is obtained by a Gauss-Newton scheme according to (6).

3 Design Method for Mamdani-type Two-degree-of-freedom PI-fuzzy Controllers

The structure of 2-DOF PI fuzzy controller is constructed by fuzzifying the main linear PI controller with the transfer function $C(s)$ in Fig. 1(b). The 2-DOF PI-FC, with the structure presented in Fig. 2, represents a discrete-time controller involving a basic fuzzy controller without dynamics (B-FC). The dynamics is inserted by the numerical differentiation of the control error e_k expressed as the increment of control error, $\Delta e_k = e_k - e_{k-1}$, and by the numerical integration of the increment of control signal, Δu_k .

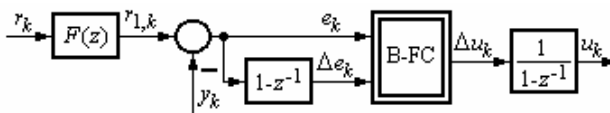

Figure 2
Structure of two-degree-of-freedom PI-fuzzy controller

B-FC is a nonlinear two inputs-single output system which includes among its nonlinearities the scaling of inputs and output as part of its fuzzification module. The fuzzification is solved in terms of the regularly distributed input and output membership functions presented in Fig. 3. Other distributions of the membership functions can modify in a desired way the controller nonlinearities. The inference engine in B-FC employs Mamdani’s MAX-MIN compositional rule of inference assisted by the rule base presented in Table 1, and the centre of gravity method for singletons is used for defuzzification.

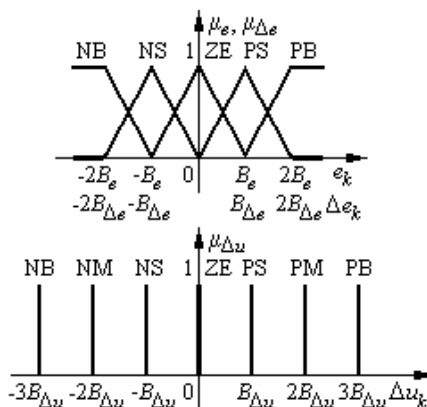

Figure 3
Membership functions of B-FC in Fig. 2

Table 1
Decision table of B-FC

Δe_k	e_k				
	NB	NS	ZE	PS	PB
PB	ZE	PS	PM	PB	PB
PS	NS	ZE	PS	PM	PB
ZE	NM	NS	ZE	PS	PM
NS	NB	NM	NS	ZE	PS
NB	NB	NB	NM	NS	ZE

Other binary operators can be introduced instead as t-norms and t-conorms instead of the MIN and MAX operators, respectively. Several representations of uninorms [14], nullnorms [15] or distance-based operators [16] can be used with this respect resulting in several versions of inference engines that can lead to FCS performance enhancement after serious analyses [17].

The design method for this class of Mamdani-type 2-DOF PI-FCs consists of the following design steps:

Step A Design the continuous-time 2-DOF PI controller by a specific method to the linear case depending on the class of considered controlled plants (in simplified mathematical models for the design) and on the desired / imposed CS performance indices.

Step B Set the value of the sampling period T_s chosen in accordance with the requirements of quasi-continuous digital control, express the discrete-time equation of the-point filter $F(z)$, the discrete-time equation(s) of the digital PI controller $C(z)$ in its incremental version:

$$\Delta u_k = K_P \cdot \Delta e_k + K_I \cdot e_k = K_P (\Delta e_k + \alpha \cdot e_k), \quad (13)$$

and compute the parameters $\{K_P, K_I, \alpha\}$, exemplified in (14) in case of Tustin's method:

$$K_P = k_C [1 - T_s / (2T_i)], \quad K_I = k_C T_s / T_i, \quad \alpha = K_I / K_P = 2T_s / (2T_i - T_s). \quad (14)$$

Step C Apply the modal equivalence principle that enables the computation of two fuzzy controller parameters, $B_{\Delta e}$ and $B_{\Delta u}$:

$$B_{\Delta e} = \alpha B_e, \quad B_{\Delta u} = K_I B_e, \quad (15)$$

where the third parameter, B_e , represents designer's option.

4 Stability Analysis Method

To perform the stability analysis of the FCS the controlled plant must be transformed to the following n -th order discrete-time SISO linear time-invariant state mathematical model (MM) including the zero-order hold:

$$\begin{aligned} \mathbf{x}_{k+1} &= \mathbf{A} \cdot \mathbf{x}_k + \mathbf{b} \cdot u_k, \\ y_k &= \mathbf{c}^T \cdot \mathbf{x}_k \end{aligned} \quad (16)$$

where: u_k – control signal; y_k – controlled output; \mathbf{x}_k – state vector, $\dim \mathbf{x}_k = (n,1)$; \mathbf{A} , \mathbf{b} , \mathbf{c}^T – matrices having the dimensions as follows: $\dim \mathbf{A} = (n, n)$, $\dim \mathbf{b} = (n, 1)$, $\dim \mathbf{c}^T = (1, n)$. In this context it is necessary to transform the initial FCS structure into a multivariable one because B-FC (see Fig. 2) represents a two inputs-single output system. This modified FCS structure is illustrated in Fig. 4(a), where the dynamics of the fuzzy controller is transferred to the controlled plant resulting in the extended controlled plant (ECP, a linear one). The vectors in Fig. 4(a) have the following representation: \mathbf{r}_k – reference input vector, \mathbf{e}_k – control error vector, \mathbf{y}_k – controlled output vector, \mathbf{u}_k – control signal vector. Generally speaking, in both discrete- and continuous-time, the index k may be omitted, and these vectors are defined in (17):

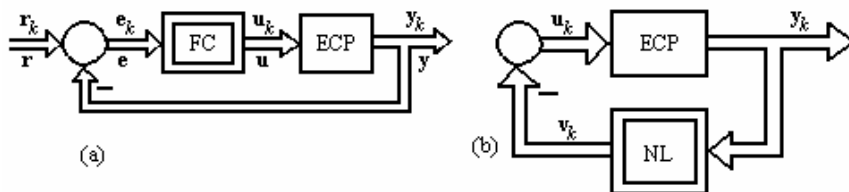

Figure 4

Modified structure of FCS (a) and structure used in stability analysis (b)

$$\mathbf{r}_k = [r_k \quad \Delta r_k]^T, \quad \mathbf{e}_k = [e_k \quad \Delta e_k]^T, \quad \mathbf{y}_k = [y_k \quad \Delta y_k]^T, \quad (17)$$

with the general notation $\Delta v_k = v_k - v_{k-1}$ for the increment of v_k .

The block FC in Fig. 4(a) is characterized by the nonlinear input-output static map \mathbf{F} :

$$\mathbf{F} : R^2 \rightarrow R^2, \quad \mathbf{F}(\mathbf{e}_k) = [f(\mathbf{e}_k), 0]^T, \quad (18)$$

where $f : R^2 \rightarrow R$ is the input-output static map of B-FC in Fig. 2.

All variables in Fig. 4(a) have two components, and this requires the introduction of a fictitious control signal, supplementary to the outputs of B-FC, to obtain equal numbers of inputs and outputs as required by the hyperstability theory in the multivariable case. In addition, the structure involved in the stability analysis of an unforced nonlinear control system ($\mathbf{r}_k = \mathbf{0}$ and the disturbance inputs are also zero)

is presented in Fig. 4(b). The block NL in Fig. 4(b) represents a static nonlinearity due to the nonlinear part without dynamics of the block FC in Fig. 4(a). The connections between the variables of the two control system structures in Fig. 4 are:

$$\mathbf{v}_k = -\mathbf{u}_k = -\mathbf{F}(\mathbf{e}_k), \quad \mathbf{y}_k = -\mathbf{e}_k, \quad (19)$$

with the second component of \mathbf{F} being always zero to neglect the effect of the fictitious control signal.

The MM of the ECP can be derived by firstly defining the additional state variables $\{x_{uk}, x_{yk}\}$ according to [18], and the $(n+2)$ -th order discrete-time state MM of the ECP can be expressed as:

$$\begin{aligned} \mathbf{x}_{k+1}^E &= \mathbf{A}^E \cdot \mathbf{x}_k^E + \mathbf{B}^E \cdot \mathbf{u}_k^E, \\ \mathbf{y}_k^E &= \mathbf{C}^E \cdot \mathbf{x}_k^E \end{aligned} \quad (20)$$

with the matrices \mathbf{A}^E ($\dim \mathbf{A}^E = (n+2, n+2)$), \mathbf{B}^E ($\dim \mathbf{B}^E = (n+2, 2)$) and \mathbf{C}^E ($\dim \mathbf{C}^E = (2, n+2)$):

$$\mathbf{A}^E = \begin{bmatrix} \mathbf{A} & \mathbf{b} & \mathbf{0} \\ \mathbf{0}^T & 1 & 0 \\ \mathbf{c}^T & 0 & 0 \end{bmatrix}, \quad \mathbf{B}^E = \begin{bmatrix} \mathbf{b} & \mathbf{1} \\ 1 & 1 \\ 0 & 1 \end{bmatrix}, \quad \mathbf{C}^E = \begin{bmatrix} \mathbf{c}^T & 0 & 0 \\ \mathbf{c}^T & 0 & -1 \end{bmatrix}. \quad (21)$$

Simple computations from the second equations in (19) and (20) lead to:

$$\mathbf{e}_k = -\mathbf{C}^E \cdot \mathbf{x}_k, \quad \mathbf{x}_k = \mathbf{C}^b \cdot \mathbf{e}_k, \quad (22)$$

where the matrix \mathbf{C}^b , $\dim \mathbf{C}^b = (n+2, 2)$, can be calculated relatively easy as function of \mathbf{C}^E .

The core of the suggested stability analysis method can be expressed in terms of one theorem offering a certain sufficient stability condition [18]. This theorem states that nonlinear system, with the structure presented in Fig. 4(b) and the MM of its linear part (20), is globally asymptotically stable if the three matrices \mathbf{P} (positive definite, $\dim \mathbf{P} = (n+2, n+2)$), \mathbf{L} (regular, $\dim \mathbf{L} = (n+2, n+2)$) and \mathbf{V} (any, $\dim \mathbf{V} = (n+2, 2)$) fulfil (23):

$$\begin{aligned} (\mathbf{A}^E)^T \cdot \mathbf{P} \cdot \mathbf{A}^E &= -\mathbf{L} \cdot \mathbf{L}^T \\ \mathbf{C}^E - (\mathbf{B}^E)^T \cdot \mathbf{P} \cdot \mathbf{A}^E &= \mathbf{V}^T \cdot \mathbf{L}^T, \\ -(\mathbf{B}^E)^T \cdot \mathbf{P} \cdot \mathbf{B}^E &= \mathbf{V}^T \cdot \mathbf{V} \end{aligned} \quad (23)$$

introducing the matrices \mathbf{M} ($\dim \mathbf{M} = (2, 2)$), \mathbf{N} ($\dim \mathbf{N} = (2, 2)$) and \mathbf{R} ($\dim \mathbf{R} = (2, 2)$) defined in (24):

$$\begin{aligned} \mathbf{M} &= (\mathbf{C}^b)^T \cdot (\mathbf{L} \cdot \mathbf{L}^T - \mathbf{P}) \cdot \mathbf{C}^b \\ \mathbf{N} &= (\mathbf{C}^b)^T \cdot [\mathbf{L} \cdot \mathbf{V} - (\mathbf{A}^E)^T \cdot \mathbf{P} \cdot \mathbf{B}^E - 2(\mathbf{C}^E)^T], \\ \mathbf{R} &= \mathbf{V}^T \cdot \mathbf{V} \end{aligned} \quad (24)$$

the Popov-type inequality (25) holds for any value of the control error e_k :

$$f(\mathbf{e}_k) \cdot \mathbf{n}^T \cdot \mathbf{e}_k + (\mathbf{e}_k)^T \cdot \mathbf{M} \cdot \mathbf{e}_k \geq 0, \quad (25)$$

where \mathbf{n} represents the first column in \mathbf{N} .

For a given value of PI-FC parameter B_e the stability analysis method is concentrated on checking the stability condition (25) for any values of PI-FC inputs in operating regimes considered as significant to FCS behaviour.

5 Case Study

The case study considered in this Section aims the validation of the suggested design method dedicated to the new class of 2-DOF PI-fuzzy controllers presented in Section 3. The case study is focused on a fuzzy controller design for the class of plants with the transfer function $P(s)$ characterizing simplified mathematical models used in servo system control as part of mechatronics systems and embedded systems:

$$P(s) = k_p / [s(1 + T_\Sigma s)], \quad (26)$$

where k_p is the controlled plant gain and T_Σ is the small time constant or an equivalent time constant as sum of parasitic time constants.

One solution to control this class of plants is represented by PI control [1]. A simple and efficient way to tune the parameters of the 2-DOF PI controller controlling the plant (16) is represented by the Extended Symmetrical Optimum (ESO) method [19], characterized by only one design parameter, β . The choice of the parameter β within the domain $1 < \beta < 20$, leads to the modification of the CS performance indices (σ_1 – overshoot, $\hat{t}_r = t_r / T_\Sigma$ – normalized rise time, $\hat{t}_s = t_s / T_\Sigma$ – normalized settling time defined in the unit step modification of r , φ_m – phase margin) according to designer's option and to a compromise to these performance indices using the diagrams presented in Fig. 5 in the situation without feedforward filter. The presence of the feedforward filter with the transfer function $F(s)$ improves the CS performance indices.

The PI tuning conditions, specific to the ESO method, are:

$$k_c = 1 / (\beta \sqrt{\beta T_\Sigma^2 k_p}), \quad T_i = \beta T_\Sigma. \quad (27)$$

These tuning conditions highlight the presence of only design one parameter, β , which simplifies the application of the IFT algorithms mentioned in Section 2 because the parameter vector becomes a scalar:

$$\boldsymbol{\rho} = \beta. \quad (28)$$

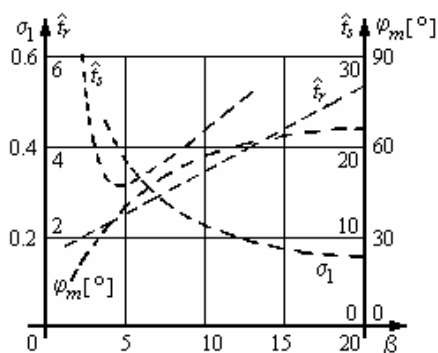

Figure 5

Control system performance indices versus β in the situation without feedforward filter

The experimental setup consists of speed control of a nonlinear laboratory DC drive (AMIRA DR300). The DC motor is loaded using a current controlled DC generator, mounted on the same shaft, and the drive has built-in analog current controllers for both DC machines having rated speed equal to 3000 rpm, rated power equal to 30 W, and rated current equal to 2 A. The speed control of the DC motor is digitally implemented using an A/D-D/A converter card. The speed sensors are a tachogenerator and an additional incremental rotary encoder mounted at the free drive-shaft. The block diagram of the hardware station is presented in Fig. 6.

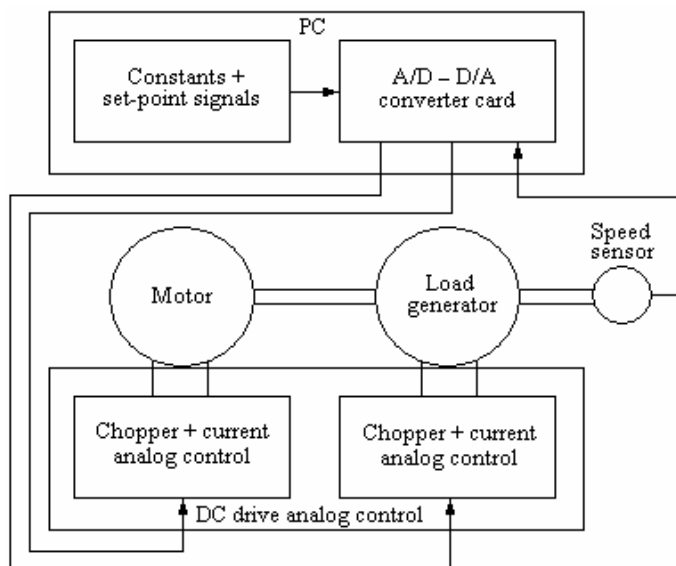

Figure 6

Block diagram of hardware station

The mathematical model of the plant can be well approximated by the transfer function $P(s)$ in (26), with $k_p = 4900$ and $T_\Sigma = 0.035$ s. The development method proposed in the previous Section is applied, and for the sake of simplicity only the main parameter values are presented. The method starts with the choice of the initial value of the design parameter $\beta = 6$. Then, a version of IFT algorithm presented in Section 2 is applied in the condition of the following c.f., J :

$$J = \frac{1}{2N} \sum_{k=1}^N (\delta y^2(k)), \quad (29)$$

in the conditions of a third-order reference model corresponding to the closed-loop linear system for the same value of β and a smaller value of T_Σ . The following ‘optimal’ values of the PI-FC tuning parameters have been obtained after six iterations: $B_e = 0.3$, $B_{\Delta e} = 0.03$, $B_{\Delta u} = 0.0021$, for $\beta^* = 5.76$. These values guarantee the FCS stability according to Section 4.

Part of the real-time experimental results – the variations of r and y versus time – are presented in Fig. 7 and Fig. 8 for the linear CS (with 2-DOF PI controller) and for the fuzzy CS (with 2-DOF PI-FC) in the conditions:

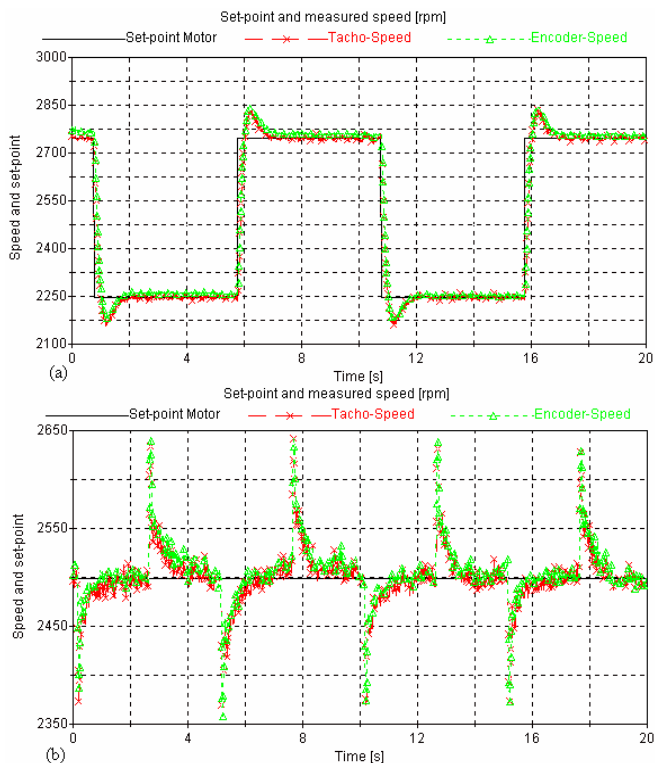

Figure 7

Control system response with 2-DOF PI controller

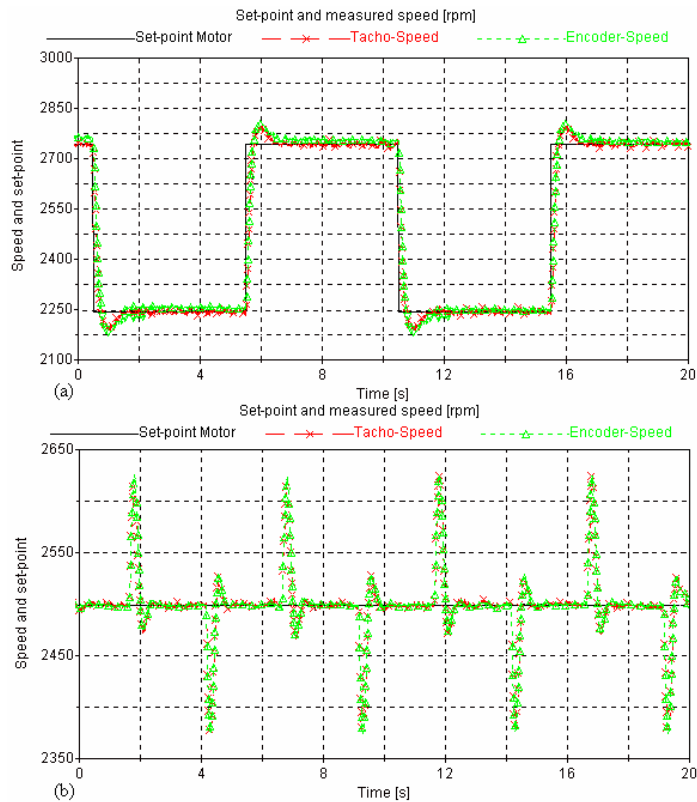

Figure 8

Control system response with 2-DOF PI-fuzzy controller

- without load in Fig. 7(a) and Fig. 8(a),
- 5 s period of 10% rated $d = d_2$ type load and $r = 2500$ rpm in Fig. 7(b) and Fig. 8(b).

Conclusions

The paper presents theoretical and application aspects concerning Iterative Feedback Tuning algorithms employed in the design of a class of fuzzy control systems with Mamdani-type PI-fuzzy controllers. It is proposed a new design method for the PI-fuzzy controllers validated by real-time experiments related one fuzzy control solution dedicated to a class of plants applied in servo systems as part of mechatronics systems and embedded systems.

The design method illustrates the potential of IFT employed in connection with fuzzy control in complex plants. The convergence of the IFT algorithms is guaranteed if the stability analysis method suggested in the paper is applied.

Future research will focus on the on-line implementation of IFT algorithms to control other laboratory equipment. This concerns discrete-event systems including robots and manufacturing systems [20, 21, 22].

Acknowledgement

The support stemming from the cooperation between Budapest Tech Polytechnical Institution and “Politehnica” University of Timisoara (PUT) in the framework of the Hungarian-Romanian Intergovernmental Science & Technology Cooperation Program no. 35 ID 17, from two CNCSIS grants, and from the cooperation in automatic control between University of Bremen and PUT is acknowledged.

References

- [1] K.-J. Åström, T. Häggglund: PID Controllers Theory: Design and Tuning, Instrument Society of America, Research Triangle Park, NC, 1995
- [2] M. Araki, H. Taguchi: Two-degree-of-freedom PID Controllers, in Int. Journal of Control, Automation, and Systems, Vol. 1, 2003, pp. 401-411
- [3] A. Visioli: A New Design for a PID Plus Feedforward Controller, in Journal of Process Control, Vol. 14, 2004, pp. 457-63
- [4] D. Driankov, H. Hellendoorn, M. Reinfrank: An Introduction to Fuzzy Control, Springer-Verlag, Berlin, Heidelberg, New York, 1993
- [5] K. M. Passino, S. Yurkovich: Fuzzy Control, Addison-Wesley, Reading, MA, 1998
- [6] S. Galichet, L. Foulloy: Fuzzy Controllers: Synthesis and Equivalences, in IEEE Transactions on Fuzzy Systems, Vol. 3, 1995, pp. 140-148
- [7] B. S. Moon: Equivalence between Fuzzy Logic Controllers and PI Controllers for Single Input Systems, Fuzzy Sets and Syst., Vol. 69, 1995, pp. 105-113
- [8] H. Hjalmarsson, S. Gunnarsson, M. Gevers: A Convergent Iterative Restricted Complexity Control Design Scheme, in Proc. 33rd IEEE Conf. on Decision and Control, Lake Buena Vista, FL, 1994, pp. 1735-1740
- [9] H. Hjalmarsson, M. Gevers, S. Gunnarsson, O. Lequin: Iterative Feedback Tuning: Theory and Applications, in IEEE Control Systems Magazine, Vol. 18, 1994, pp. 26-41
- [10] O. Lequin, M. Gevers, M. Mossberg, E. Bosmans, L. Triest: Iterative Feedback Tuning of PID Parameters: Comparison with Classical Tuning Rules, in Control Engineering Practice, Vol. 11, 2003, pp. 1023-1033
- [11] K. Hamamoto, T. Fukuda, T. Sugie: Iterative Feedback Tuning of Controllers for a Two-mass-spring System with Friction, in Control Engineering Practice, Vol. 11, 2003, pp. 1061-1068

- [12] C. Ardelean, A. Graeser, M. Mihajlov, R.-E. Precup: Applications of Iterative Feedback Tuning in PID Controller Design, in *Buletinul Stiintific al Universitatii "Politehnica" din Timisoara, Transactions on Automatic Control and Computer Science*, Vol. 50 (64), No. 1, 2005, pp. 11-16
- [13] R.-E. Precup, S. Preitl: Optimisation Criteria in Development of Fuzzy Controllers with Dynamics, in *Engineering Applications of Artificial Intelligence*, Vol. 17, 2004, pp. 661-674
- [14] J. Fodor, R. Yager, A. Rybalov: Structure of Uninorms, in *International Journal of Uncertainty, Fuzziness and Knowledge-Based Systems*, Vol. 5, 1997, pp. 411-427
- [15] T. Calvo, B. De Baets, J. Fodor: The Functional Equations of Frank and Alsina for Uninorms and Nullnorms, in *Fuzzy Sets and Systems*, Vol. 120, 2001, pp. 385-394
- [16] I. Batyrshin, O. Kaynak, I. Rudas: Fuzzy Modeling based on Generalized Conjunction Operations, in *IEEE Transactions on Fuzzy Systems*, Vol. 10, 2002, pp. 678-683
- [17] M. Takács: Approximate Reasoning in Fuzzy Systems Based on Pseudo-Analysis, PhD Thesis, University of Novi Sad, 2004
- [18] R.-E. Precup, S. Preitl: Stability and Sensitivity Analysis of Fuzzy Control Systems. Mechatronics Applications, in *Proc. 6th International Symposium of Hungarian Researchers on Computational Intelligence*, Budapest, Hungary, 2005, pp. 130-143
- [19] S. Preitl, R.-E. Precup: An Extension of Tuning Relations after Symmetrical Optimum Method for PI and PID Controllers, in *Automatica*, Vol. 35, 1999, pp. 1731-1736
- [20] L. Horváth, I. J. Rudas, O. Kaynak: Virtual Manufacturing Oriented Generic Manufacturing Process Model, in *Recent Advances in Mechatronics*, Springer-Verlag, 1999, pp. 336-348
- [21] L. Horváth, I. J. Rudas, C. Couto: Integration of Human Intent Model Descriptions in Product Models, in *Digital Enterprise - New Challenges Life-Cycle Approach in Management and Production*, Kluwer Academic Publishers, 2001, pp. 1-12
- [22] L. Horváth, I. J. Rudas, J. F. Bitó, A. Szakál: Adaptive Model Objects for Robot Related Applications of Product Models, in *Proc. 2004 IEEE International Conference on Robotics & Automation ICRA 2004*, New Orleans, LA, USA, 2004, pp. 3137-3142